

Identification of Acoustic Resonant Modes of General Aviation Aircraft Cabin Interior

Dubravko Miljković¹, Jurica Ivošević², Tino Bucak²

¹ HEP Zagreb, Croatia, Email: dmiljkovic@hep.hr

² Faculty of Transport and Traffic Sciences, University of Zagreb, Croatia,

Abstract - Cabin interiors of a general aviation aircraft has dimensions that favor formation of standing waves (resonant modes) in the range of noise and fuselage vibration modes frequencies caused by excitations from the engine/propeller propulsion combination and engine exhaust system. Frequency response functions of the cabin interior for the general aviation aircraft are determined using the MLS and TSP method. Measured values are compared with simplified calculations obtained from the available cabin dimensions. Knowledge of these resonant modes may help when devising passive and active methods for noise reduction within general aviation aircraft interior.

Introduction

Aircraft cabin noise is produced by various sources (propeller, engine, exhaust and airstream along fuselage), [1, 2] and is modified by the cabin frequency response. Some frequencies are attenuated more than others. In an enclosure, such as the interior of an aircraft, the sound field is reverberant and causes standing waves at certain frequencies. Aircraft used in an experiment was Cessna 172 S (Figure 1).

Acoustic measurements

The impulse response is a transfer function between the signal source and the receiver. When it is measured in a aircraft cabin, the impulse response includes the information of sound reflection, absorption, and reverberation. Measurements were performed using the MLS (Maximum Length Sequence) and TSP (Time Stretched Pulse) method, [3], (sample rate 44.1 kHz). The sound source was placed under the instrument panel and the microphone was moved across all seat positions at the head level. MLS measurements appear a little bit noisier than TSP, [4]. Due to



Figure 1 Cessna 172S G1000



Figure 2 Cessna 172S interior

the excellent acoustic absorption properties of quality materials used for the interior furnishing in a new model of Cessna 172S aircraft (including leather seats), Figure 2, reflections fade out quite quickly and cabin resonances are not very pronounced. The impulse response is almost zero after approx. 100 ms, (Figure 3). Results of measurements at pilot, copilot, left and right rear passenger seats are shown in Figures 4-15. Little more reflections are noted in impulse responses with measurements carried out with the microphone positioned at rear seats (sound travels the longer path from the measurement source to the microphone).

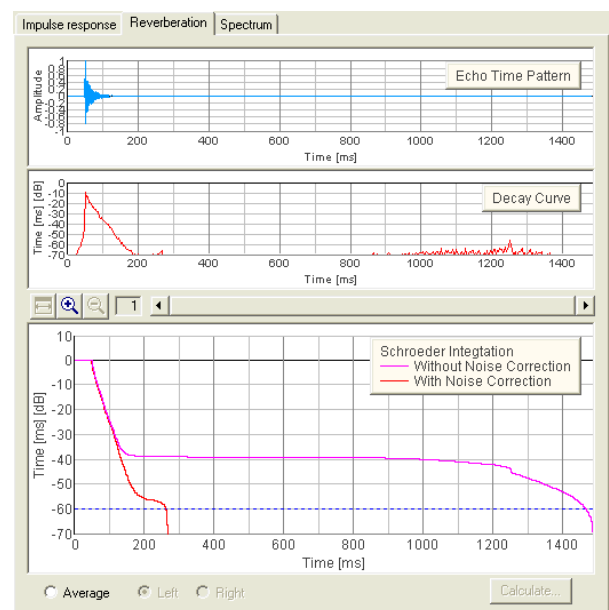

Figure 3 Impulse response, decay curve and Schroeders integration

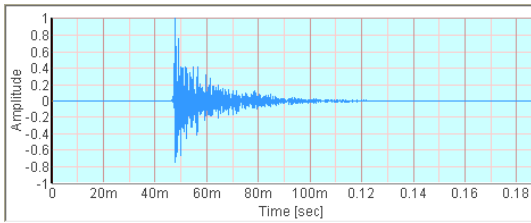

Figure 4 Pilot seat - TSP

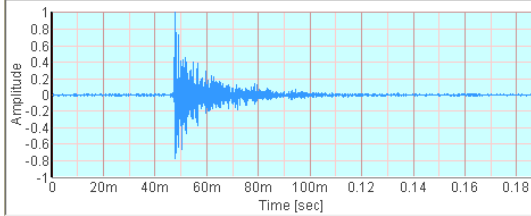

Figure 5 Pilot seat - MLS

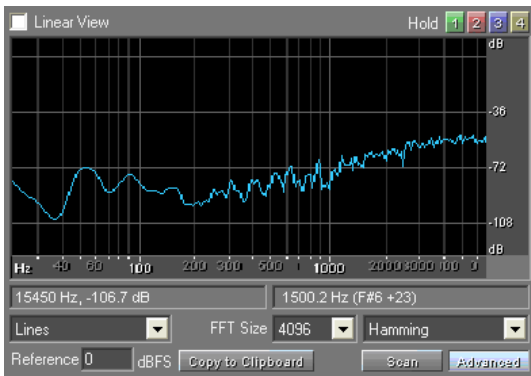

Figure 6 Pilot seat

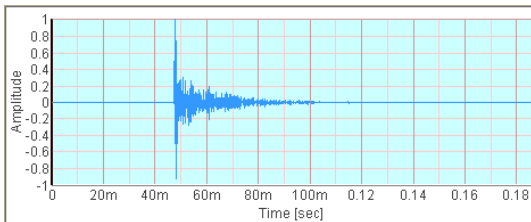

Figure 7 Copilot seat - TSP

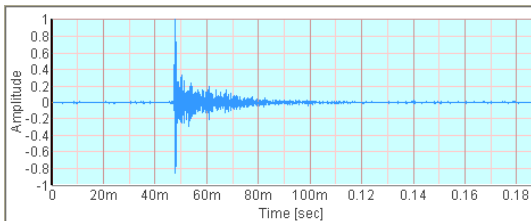

Figure 8 Copilot seat - MLS

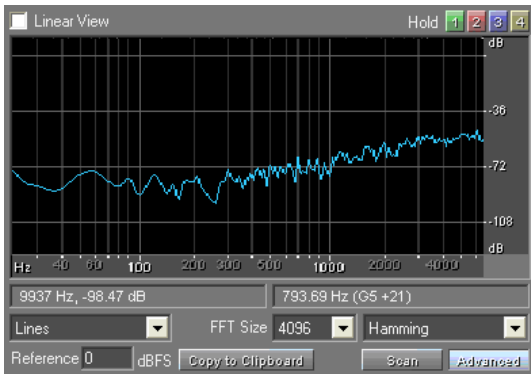

Figure 9 Copilot seat

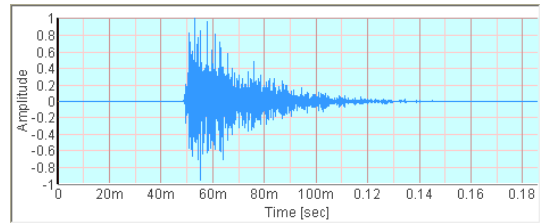

Figure 10 Left rear passenger seat - TSP

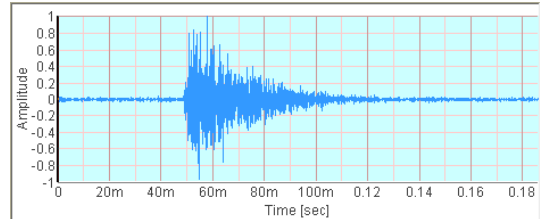

Figure 11 Left rear passenger seat - MLS

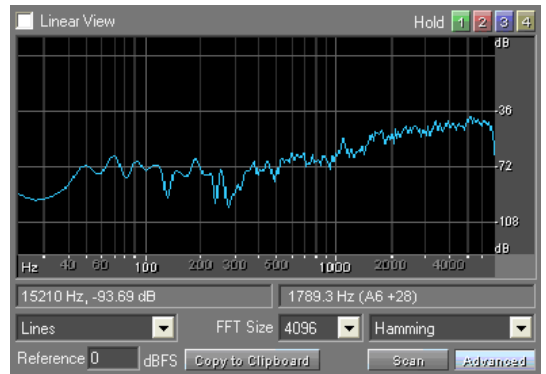

Figure 12 Left rear passenger seat

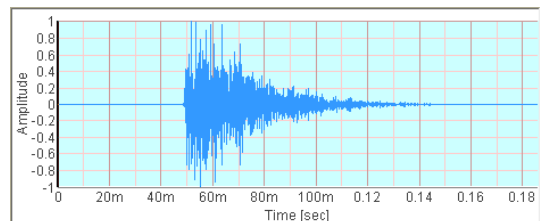

Figure 13 Right rear passenger seat - TSP

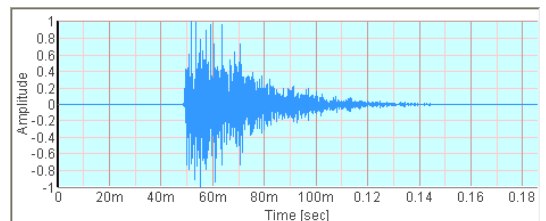

Figure 14 Right rear passenger seat - MLS

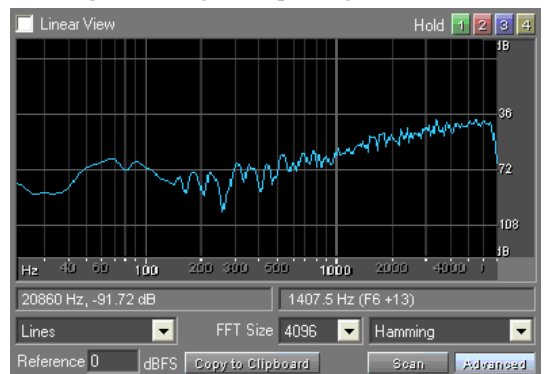

Figure 15 Right rear passenger seat

Cabin axial acoustic modes

Frequency responses were calculated using the Fourier transform of measured TSP (less noisy) impulse responses. From the measurement obtained at the pilot seat position following nodes (minimuns) and anti-nodes (maximums) were determined analyzing the frequency response curve (Figure 6, Table 1 and 2):

Mode	Frequency (Hz)
1	53
2	92
3	150
4	204
5	247

Table 1 Anti-nodes

Mode	Frequency (Hz)
1	32
2	64
3	129
4	183
5	226

Table 2 Nodes

Cabin as the rectangular enclosure

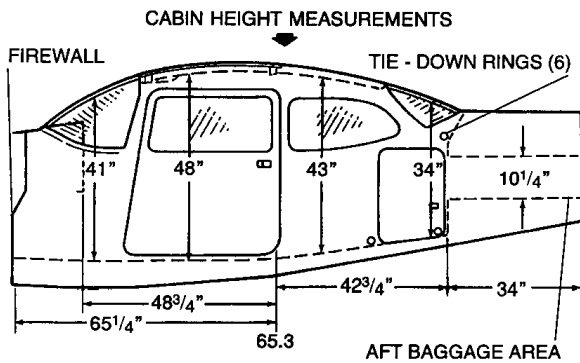

Figure 16 Cessna 172 cabin dimensions

The Cessna 172 cabin is illustrated in Figure 16. The cabin dimensions (maximal values) are shown in Table 3.

Length (<i>L</i>)	3.607 m
Height (<i>H</i>)	1.219 m
Width (<i>W</i>)	1.003 m

Table 3 Cabin dimensions

The rectangular model of the cabin (the rude approximation – cabin is of a more complex shape, includes leather seats and sidewall furnishing) was used for determination of cabin axial acoustic modes. Axial modes involve two parallel surfaces - opposite parallel walls, or the floor and ceiling as shown in Figure 17 from [5]. These are the strongest modes.

Axial Room Resonance Modes

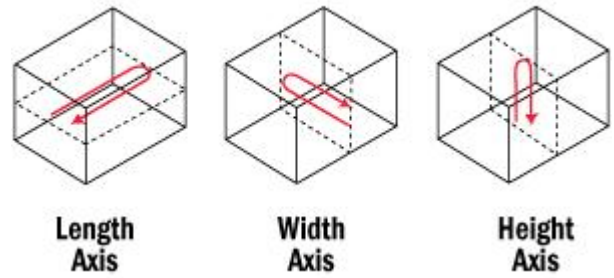

Figure 17 Axial resonance modes, [5]

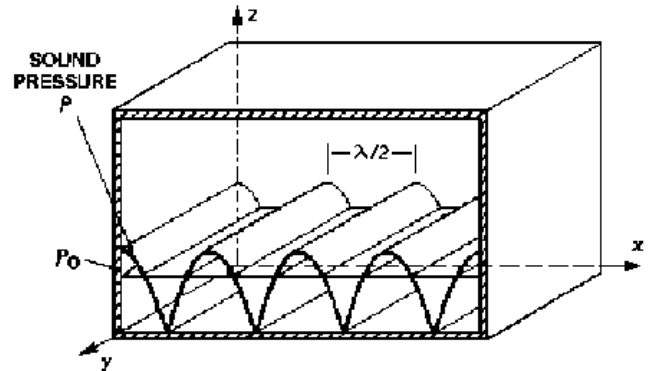

Figure 18 Axial modes of rectangular enclosure (in direction of x axis), [5]

There are always sound pressure maxima (anti-nodes) at the walls (Figure 18), [5].

Considering that axial standing waves have wavelengths that equals to the cabin dimension *D* (in the direction of the particular axis) and its integer fractions, corresponding frequencies can be calculated from (*c* is the speed of sound):

$$f_k = \frac{kc}{2D} \quad k = 1, 2, 3, \dots \quad [\text{Hz}] \quad (1)$$

For the various axes, *D* takes values *L*, *H* or *W* from the Table 3.

Cabin dimensions were entered into the available web calculator, [5], and following axial modes were calculated (Table 4).

47.54643 Hz	170.9870 Hz	140.6890 Hz	95.09287 Hz	341.9740 Hz	281.3781 Hz
142.6393 Hz	512.9611 Hz	422.0672 Hz	190.1857 Hz	683.9481 Hz	562.7563 Hz
237.7321 Hz	854.9351 Hz	703.4454 Hz	285.2786 Hz	1025.922 Hz	844.1345 Hz
332.8250 Hz	1196.909 Hz	984.8236 Hz	380.3714 Hz	1367.896 Hz	1125.512 Hz
427.9179 Hz	1538.883 Hz	1266.201 Hz			

Table 4 Calculated axial modes

More complex tangential and oblique room modes were not calculated considering the great simplification in assumed rectangular shape of the cabin that would influence the accuracy of results even more than for axial modes.

Modes of empty rectangular space can be precisely determined, but the more complex shape of the cabin may significantly change results of otherwise simple computations.

Conclusion

Acoustic resonant modes of the most popular general aviation aircraft (Cessna 172S) have been determined from measured impulse responses. The comparison of the results obtained from the measurements of the cabin impulse response with the calculated modes under assumption of the rectangular cabin shape shows great shortcomings of using simple cabin model for the determination of even the lowest few acoustic modes. The lowest resonance was determined with acceptable accuracy (10% error). More complex models using finite elements methods should be used instead.

Acknowledgements

This study is a part of the project No. 135-1352339-2349 supported by the Ministry of Science, Education and Sports of the Republic of Croatia.

References

- [1] D. Miljković, M. Maletić i M. Obad: Comparative Investigation Of Aircraft Interior Noise Properties, Proc. of 3rd Congress of the Alps Adria Acoustics Association, Graz, Austria, 2007
- [2] D. Miljković, J. Ivošević and T. Bucak, Two vs. Three Blade Propeller - Cockpit Noise Comparison, Proc. of 5th Congress of the Alps Adria Acoustics Association, Petrčane, Croatia, 2012
- [3] D. Havelock, S. Kuwano and M. Vorländer (Eds), Handbook of Signal Processing in Acoustics, Springer, Germany, 2008
- [4] G. B. Stan, J. Jacques and D. Archambeau, Dominique Comparison of different impulse response measurement techniques, JAES Volume 50 Issue 4 pp. 249-262; April 2002
- [5] Calculation of the three room modes, URL: <http://www.sengpielaudio.com/calculator-roommodes.htm>