



International Colloquium Transformer Research and Asset Management

Cavtat, Croatia, November 12 – 14, 2009

Mladen Banović
Končar- Electrical Engineering Institute, Zagreb
mbanovic@koncar-institut.hr

Antun Mikulecky
Končar-Electrical Engineering Institute, Zagreb
amikul@koncar-institut.hr

CONCEPT FOR RESEARCH OF COMBINED ELECTRIC FIELD AT LIGHTNING IMPULSE TEST FOR HV WINDINGS

SUMMARY

The goal of this research is to qualify and to quantify the influence of radial stress on axial stress of transformer coil insulation at lightning impulse test. Combined electric field is investigated experimentally using complex models that simulate both radial and axial electric field. The models are made of flat wire and continuous transposed conductor (CTC), with different insulation increases and different spacer thickness. They will be vacuum dried and oil impregnated and will be tested in high voltage laboratory using lightning impulses in appropriate incremental steps. Because of statistical evaluation, 12 identical models of the same type (geometry) will be tested. Total number of model types including flat wire and CTC is 48. Partial discharges during lightning impulse testing will be checked too. Various potential design criteria, such as simple combined field stress, maximal electric field on the insulated conductor, safety factor along electric field line, stressed space and streamer criterion will be checked on the basis of the electric field calculated for the actual models geometry and obtained breakdown voltages. Paper describes all the basic steps in experimental investigation of combined stresses in transformer HV winding including models design and LI testing procedure.

Key words: power transformer, winding insulation, model, lightning impulse, partial discharge

1. INTRODUCTION

High voltage (HV) transformer windings are produced from various types of discs or coils with or without spacers between them. During lightning impulse (LI) testing, the electric field between coils is dominantly axial and it depends on the geometry and voltage distribution along HV winding that varies from slightly to highly nonlinear. HV winding is generally placed around LV winding in the transformer. Radial distance between them is called main gap. The electric field in the main gap is dominantly radial and it depends also on geometry and voltage distribution. Transformer designers usually consider axial stresses between discs (coils) in HV windings and radial stresses between windings in separate manner - as two mutually independent features, which transformer should withstand both. That is so because of historical reasons: withstand voltages between discs and withstand voltages between windings were investigated on separate models that exclude one each another. Higher paper thickness increases the withstand voltage between the discs but it considerably decreases their cooling properties. Basically similar situation is with spacer thickness. Increasing of the spacer thickness results in increase of the withstand voltage between the discs, but that affects winding cooling properties and deteriorates the HV voltage distribution (increasing of LI voltage between coils, especially for non interleaved windings). Average LI electric field is decreasing with spacer thickness increase but its inhomogeneity raises. In all senses mentioned above, the optimal paper and spacer thickness should be used. From the transformer designer and the customer point of view, joining of axial and radial stresses in single design criterion, expressed in an electric field value of combined stress, point stress or so, leads to the appliance of higher

spacer thickness (reducing of winding fill factor), interleaved or special types of inhomogenous windings (which have a huge number of soldering points - potential weak place). As another result of appliance of the combined stress criterion, some HV winding types that have been widely and satisfactorily used for a long time can no longer be applied.

As is said above joining radial and axial electric field in a single design criterion has a big impact on the HV transformer design. This work can contribute to the clarification of that problem. As it is well known, no widely accepted breakdown theory exists. Because of that, research of the radial electric field influence to the axial electric field will be done experimentally, on special models which simulate both radial and axial electric fields.

2. MODELS DESCRIPTION

Two basic types of models are investigated: models with magnitude of radial electric field stress as commonly used in transformer design, and models with negligible radial stress. Total planned number of models, as shown in figure 1, is 576.

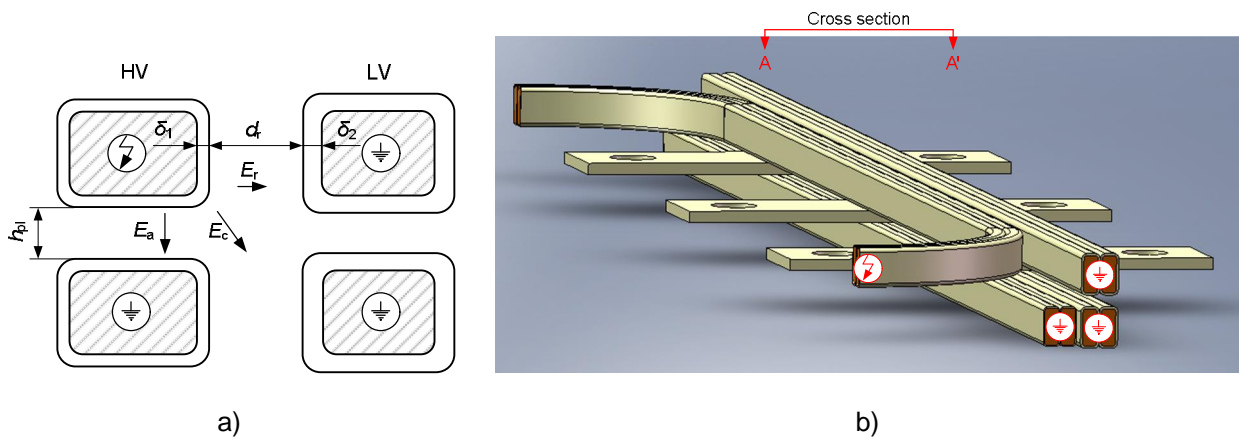

Figure 1: The model for researching of combined electric field, a) cross section, and b) 3D view

Manufactured models made of flat wire are presented in figure 2. Six models are placed in one special frame which enables their axial and radial tightening. The models in two frames have the same characteristics and constitute a set of models. Each set of main models has a control set of models. The difference between the main and the control set of models is in the magnitude of radial field (E_r , fig. 1a.) which is negligible in control models. In main model the magnitude of E_r is adjusted to the value that corresponds to design electric field value in main duct for real transformer at LI testing. The radial electric

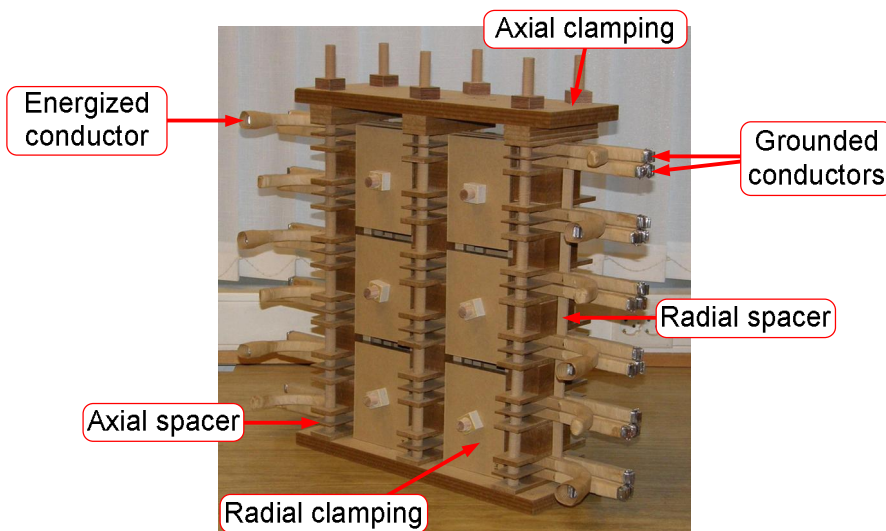

Figure 2: Manufactured models, built in a appropriate frame for manipulation and testing

field magnitude is adjusted by radial distance d_r , figure 1.a, using radial spacers, figure 2. The control models have a few time thicker radial spacers d_r than the main models. All other characteristics of these two sets of models are completely the same. Three conductors that are not energized during LI test are connected and grounded. Investigation is performed for conductor insulation thickness (d_1) in the range from 0,4 mm to 0,8 mm and axial spacer thickness (h_p) from 0 mm (no spacer) to 6 mm. The length of wires exposed to the desired stress (exposed length of the model) is about 0,45 m.

After fabrication, main and control models are altogether vacuum dried, compressed in axial and radial direction, figure 2, and oil impregnated with good quality mineral oil. Main and control models are placed and tested in the same testing vessel, figure 3. The chosen investigation concept, that includes main and control models, assures minimizing all other influencing factors except magnitude of radial electric field E_r . That enables good comparison of breakdown voltages between models. The breakdown voltage of oil from each test vessel was checked prior to testing.



Figure 3: Models under testing (left: models under oil in the test vessel, right: test arrangement in HV laboratory)

3. TESTING DESCRIPTION

Models are tested with LI in steps (negative polarity, shape 1,2/50 μ s, full wave), starting at 60 % of calculated design withstand voltage, up to the breakdown voltage. Steps are not linearly distributed in the whole range, but increments are greater for the voltages below the 100 % of design withstand voltage, and lower (about 3 % of design withstand voltage) for the voltages above this value. Three impulses are applied for each voltage step. Total number of applied impulses until the breakdown per each model is normally greater than 60. Relatively low voltage increment between steps, large number of applied impulses, 12 individual models per each configuration and relatively large exposed length of the model assure that the obtained mean breakdown voltage value is reliable. Testing is, however, time consuming. PD is checked at each test by using special measuring impedance connected in series with the model. Example of PD appearance during LI testing is shown on figure 4. On the upper oscillogram a test without PD is shown, and test with PD is presented on the bottom oscillogram.

3.1. Post testing investigation

After the testing models are disassembled, the breakdown evidence for each model unit is found and the exact location of breakdown is identified and recorded. In the end, breakdown locations are classified, by the side of energized conductor where the breakdown is found, as L (left), M (middle), and R (right). An example of model breakdown is presented in figure 5.

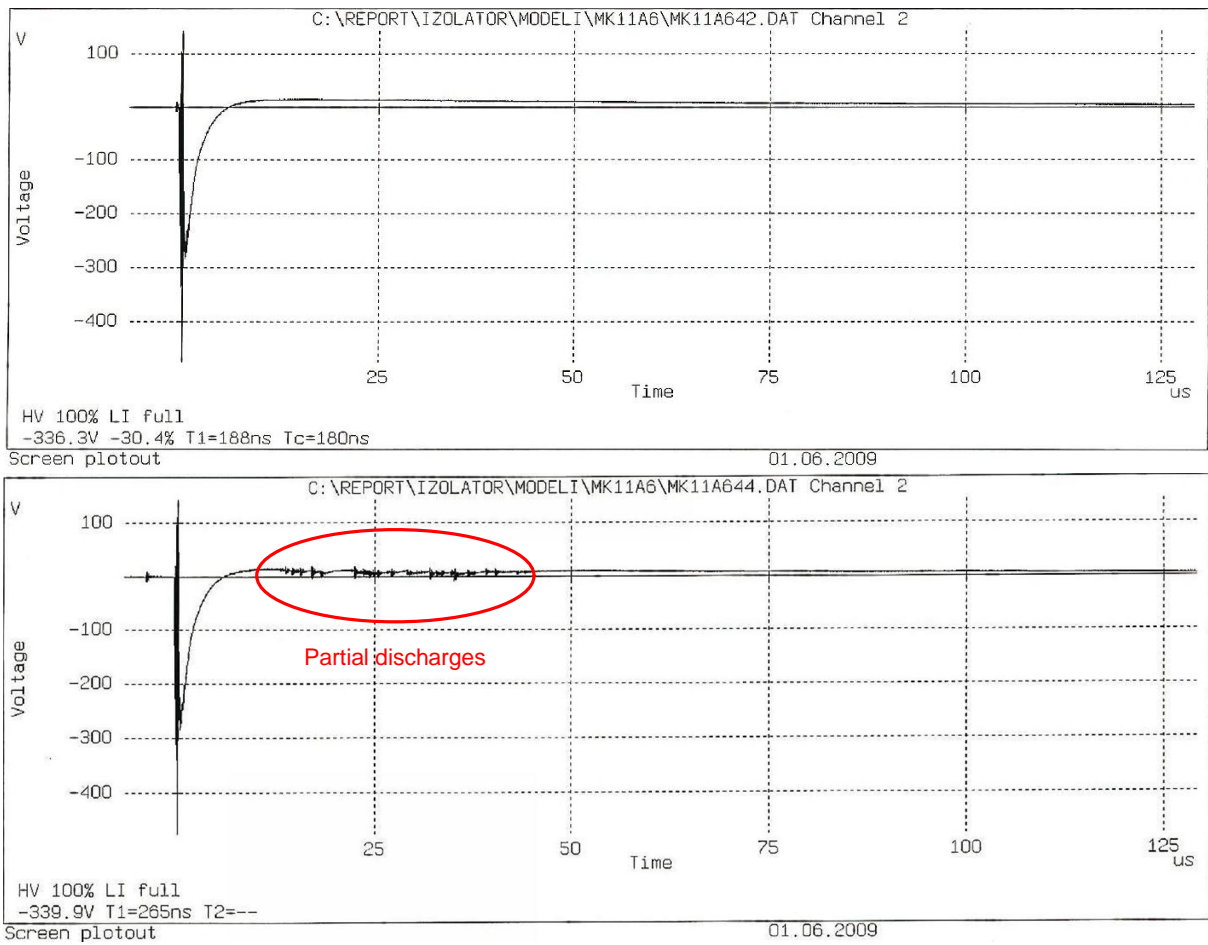

Figure 4: PD detection at LI - voltage across measuring impedance (upper: without PD, bottom: with PD)



Figure 5: The evidence of model breakdown

The classification of breakdown locations for one set of main and control models is presented in figure 6. The strong grouping of breakdown locations on the right side of energized conductor of main models is visible in figure 6.a, while the breakdowns in control models are equally distributed on both

conductor sides, figure 6.b. On the basis of this finding from the first results, it can be concluded that the radial field in the main model had a significant influence on the location of model breakdown.

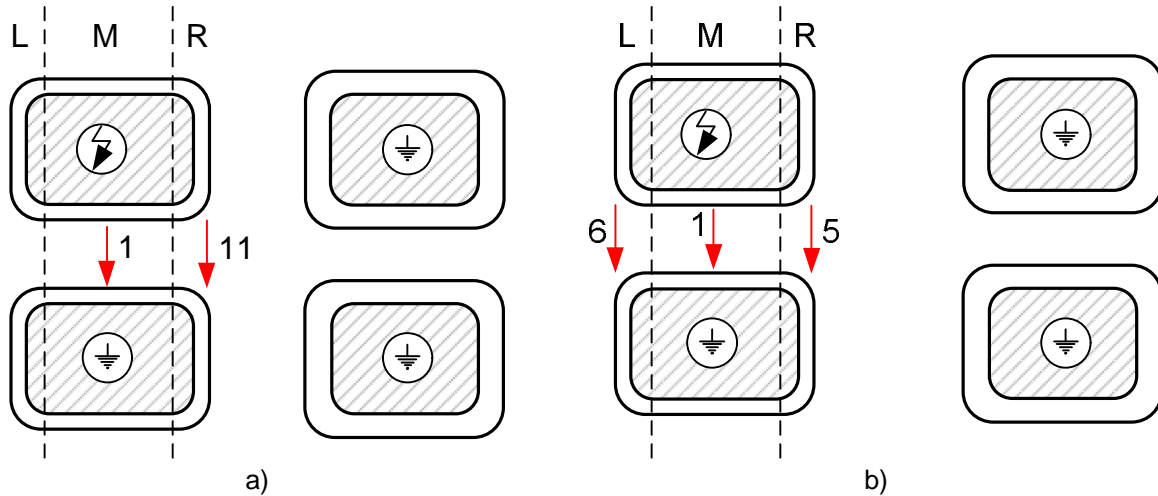

Figure 6: The classification of model breakdown locations (number of breakdowns) for: a) the set of main models, and b) the set of control models

The relation between breakdown locations and spacer thickness (channel width) for models made of flat wire is presented in figure 7. The grouping of breakdowns on the right conductor side for wider channels in the main models is obvious, figure 7.a, while this grouping lacks for control models, figure 7.b. This addresses the influence of radial field on breakdown location in main models, while there is no strong relation between these variables in control models.

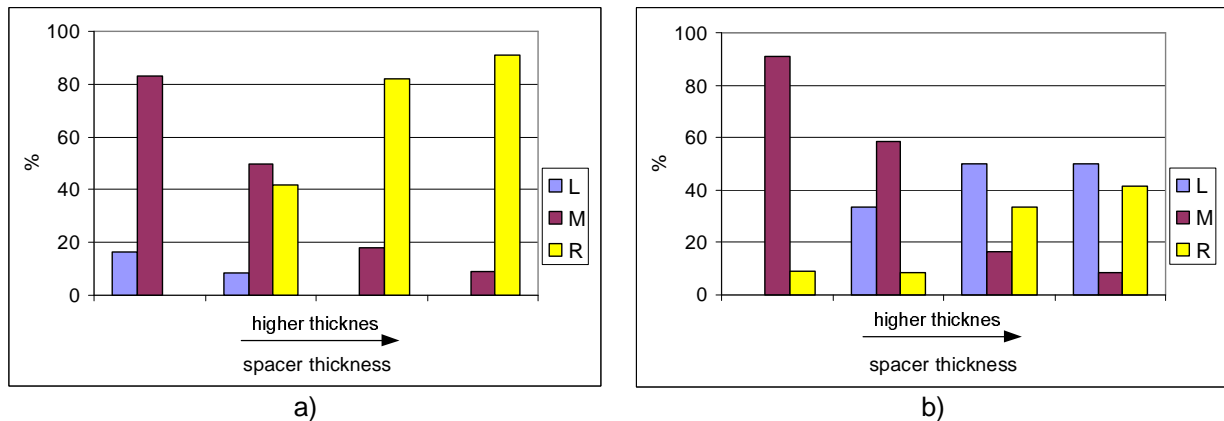

Figure 7: Relation of breakdown locations and spacer thickness (channel width) for a) the set of main models, and b) the set of control models

Breakdown voltage of the set of models is statistically analysed, outliers have been removed and mean value, standard deviation, range from minimum to maximum value and withstand voltage of the model have been determined. Mean value of breakdown voltage and withstand voltage are used for electric field calculation.

4. DESIGN CRITERIA RESEARCH

Aim of this research is to qualify and to quantify the influence of radial stress between windings (in main gap) on axial stress between HV winding discs (coils) at lightning impulse test. Qualification of the radial electric field influence can be made simply by comparison of the results for main and control models because the difference between them is only in radial electric field. Quantification of that influence is a much harder task which includes a definition of the new design criteria. But how can we define them? We decide to test various possible design criteria and make the decision considering the logical and

theoretical expectations that they have to meet, and of course, on their applicability in transformer design process (in the sense of calculation possibilities, etc.). All available design criteria are based on more or less complex obtained electric field values, such as simple obtained combined field stress, maximal electric field on the insulated conductor, safety factor along electric field line, stressed space and streamer criterion. Their short explanation is as follows.

4.1. Combined field stress

Combined field stress can be calculated by using (1):

$$E_k = \sqrt{E_r^2 + E_a^2} = \sqrt{\left(\frac{U_r}{k \cdot d_{er}}\right)^2 + \left(\frac{U_a}{d_{ea}}\right)^2} \quad (1)$$

Symbols at (1):

E_k – combined electric field stress in oil, in kV/mm

E_r – radial electric field in main duct, in kV/mm

E_a – axial electric field between discs, in kV/mm

U_r – LI voltage in the radial direction (between windings, calculated value) in kV

U_a – LI voltage in the axial direction (between discs, calculated value) in kV

d_{er} – equivalent radial distance (equivalent thickness of main duct in respect of oil), in mm

d_{ea} – equivalent axial distance (equivalent thickness of channel between discs in respect of oil), in mm

k – geometry dependant factor (for planar geometry, as it is for used models, $k=1$)

Combined field stress calculated with (1) is an artificial value and that is a disadvantage in physical sense. On the contrary, calculation is simple and predictive (no need for FEM, preprocessing and postprocessing).

4.2. Maximal electric field on the insulated conductor

Maximal electric field on the insulated conductor can be calculated by using FEM solver and a program for automatic generation of FEM models. That is necessary because of complex geometry and the need to obtain results as fast as possible. Maximal electric field is a real value in physical sense which is an advantage, but because of relatively large electric field inhomogeneity some problems with FEM methods can occur. The example of maximal electric field calculation for flat conductor model is on figure 8 (FEM model) and on figure 10 (equipotential lines and shaded electric field).

4.3. Safety factor along electric field line

Safety factor (margin) along electric field line is a well known method especially in HV main insulation design, [1]. Method can be roughly explained by (2) to (4):

$$\sigma(x) = \frac{E_w(x)}{E(x)} \quad (2)$$

$$E_w(x) = \frac{k_{LI} \cdot 21,5}{\sigma_0} x^{-0,37} \quad (3)$$

$$\bar{E}(x) = \frac{1}{x} \int_{x=0}^x E(x) dx \quad (4)$$

Symbols at (2) to (4):

$\sigma(x)$ – safety factor for certain field line

x – length or length coordinate of the certain field line

$E_w(x)$ – withstand electric field

$\bar{E}(x)$ – average electric field from $x=0$ to x

$E(x)$ – electric field along certain field line transferred to decreasing function

k_{LI} – conversion factor LI to AC

σ_0 – initial margin

Procedure is as follows: After automatic generation of FEM model and electric field calculation, electric field along number of field lines should be obtained (field lines should be chosen closely one to another) and transferred to decreasing function (if necessary). After that, average electric field is to be calculated for each field line. At the end safety factor is calculated for each field line and the minimum value for each field line is recorded. All of the values, for an appropriate design, should be greater than 1. Basic advantages of this method are a pretty good background and it's wide usage in HV insulation design. Disadvantages are the complexity and uncertainty of conversion factor LI to AC. (Originally, withstand voltage is based on Kappeler curves which express 60 s PD inception AC voltage, [1].) Example of safety factor along electric field line calculation results for flat wire model is on figure 12 which shows electric field lines, and on figure 13 which shows minimum safety factor values for certain field lines. It is fairly important to notice that minimum safety factor value and maximum electric field value do not lie on the same field line as is often in simple arrangements. Actually field line with minimum safety factor and field line with maximum el field can be pretty far one from another.

4.4. Stressed space

Stressed space (volume) is based on the fact that withstand electric field is dependant on stressed space. That space can be defined in various ways. One of the common definition is that the stressed space is bounded by the surface of the insulated electrode on which the maximum electric field (E_{max}) appears and the line (in 2D or the surface in 3D problems) which connects points of $0,9 E_{max}$, figure 11. A disadvantage of the method, besides the complexity, is the lack of wider acceptance of stressed space criterion in transformer community.

4.5. Streamer criterion

Streamer criterion is based on breakdown theory in gaseous dielectrics which is adapted for paper-oil insulation [4]. Self sustained discharge (PD or breakdown) is expressed with (5):

$$a_0 = \int_{x_k} \left(\frac{E}{E_0} \right)^z dx \quad (5)$$

Symbols at (5):

E_0 – reference electric field for reference distance a_0 in oil

$E(x)$ – electric field along field line

z – exponent

x_k – marked integration along critical electric field line

Reference electric field is a function of reference distance, voltage duration and electrode surface condition (bare or paper coated electrode). Exponent is a function of insulating media; value for transformer oil should be used. Critical electric field line is obtained by method of trials (generally in the same way as for 4.3.). Disadvantages of this method are the complexity (special preprocessors and postprocessors should be used) and uncertainty of influencing factors. Also, as is stated in [4] validity of this method regarding to LI is limited to very small clearances.

5. ELECTRIC FIELD CALCULATION

For each physical model a FEM model for 2D electric field calculation is created, figure 8. The field is calculated using Infolytica ElecNet program. Because of the huge number of different types of models and types of copper shape used, and because of the problems with model generation a special program for automatic generation of FEM models is developed. In this program, the user should choose the type of conductor (flat or CTC), the number of wires or single strips, the paper thickness, the enamel thickness, the radial and axial spacers thickness, and the vertical position of a single strip that is in transposition for CTC conductor. On the basis of entered parameters, the program creates scripts for FEM model generation and exports the data from the solved model to the table calculator for further processing. Created models of flat and CTC conductor are presented in figures 8 and 9, respectively.

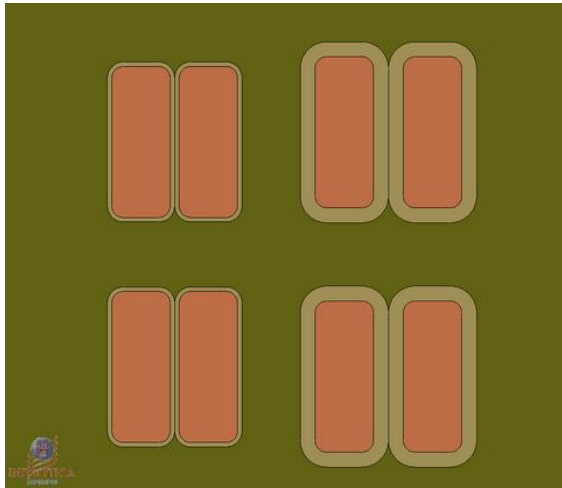

Figure 8: The FEM model of flat conductor (two wire in parallel), prepared for calculation

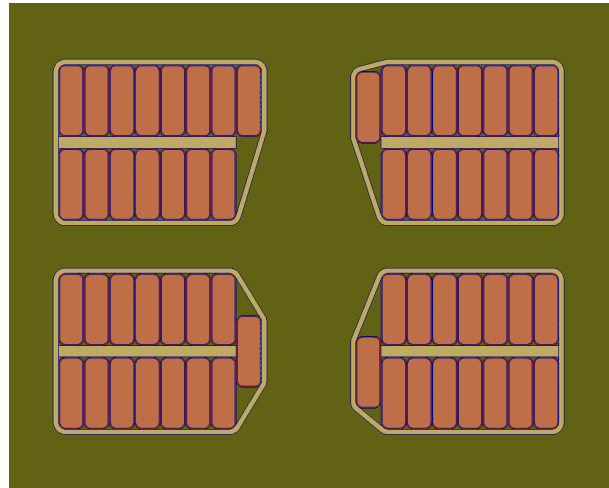

Figure 9: The FEM model of CTC conductor (fifteen single strips in parallel), prepared for calculation

For the sake of simplicity, the computation is carried out for the voltage of 100 V. Because of this all values of electric field must be recalculated to the mean breakdown voltage or withstand voltage, and than these values can be used in other analyses. An example of field solution in model of flat conductor is presented in figure 10.

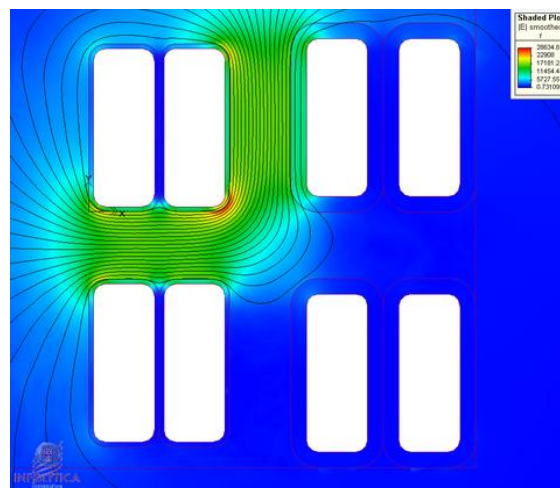

Figure 10: Computed electric field in the model of flat wire

Using the above-mentioned developed tools for the extraction of data from ElecNet solved model, different analysis are automatically applied. At first, maximum electric field (E_{max}) on the oil-paper border is found, figure 11. In this situation, it is always located on the bottom-right corner of the energized conductor. After this a stressed space border is revealed, and the area of this space in oil is computed. Also the field line from the point of maximum field is traced. The field along this line is retrieved and safety factor is calculated. It was presumable that the minimum safety factor will be for this field line.

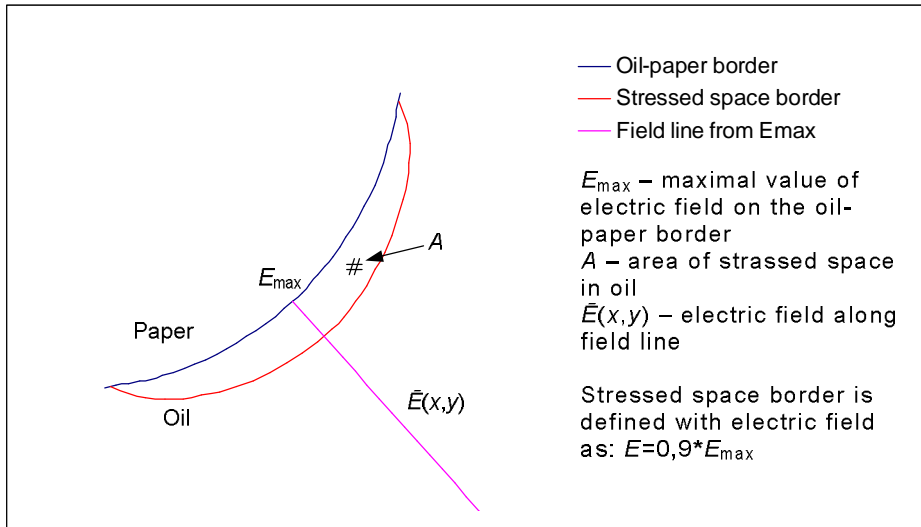

Figure 11: Parameters of the model resulted form field calculation and post calculation analysis

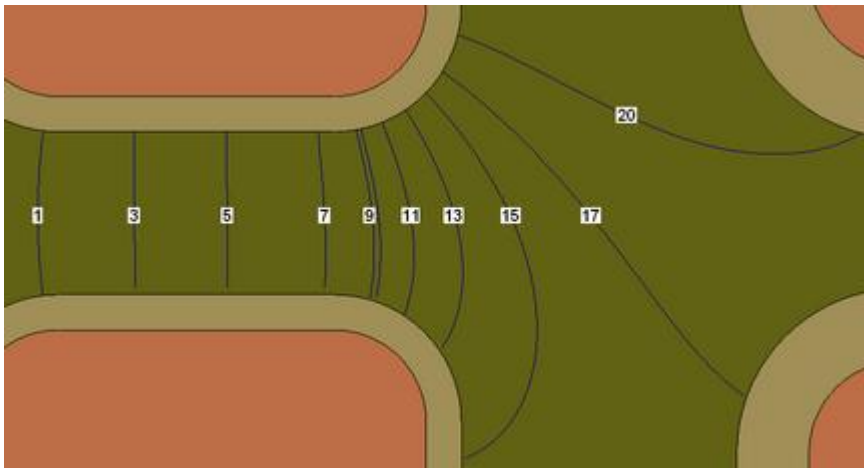

Figure 12: Investigation of the location of field line with minimum safety factor

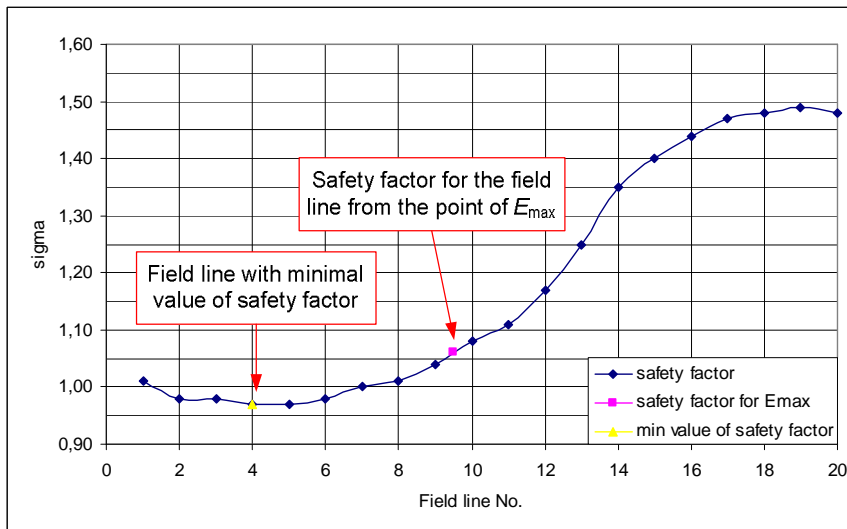

Figure 13: Values of safety factors calculated for field lines from figure 12

A detailed research is done to identify the field line with minimum safety factor. Several field lines around the bottom and right conductor side are traced and belonging safety factors are computed, figure 12. It is found that the field line from the point of maximum field is not related to the minimum safety factor, but this line, in our case, was always found between field lines No. 4 and 5, for main as well as for control models, figure 13.

6. CONCLUSION

Joining radial and axial electric field in a single design criterion so called combined stress, point stress or so, has a big impact on HV transformer design. This work can contribute to the clarification of that problem. Because no widely accepted breakdown theory exists, research of the radial electric field influence to axial electric field will be done experimentally, on special models which simulate both electric fields.

Models are tested with LI in steps. Relatively low voltage increment between steps, large number of applied impulses, 12 individual models per each configuration and relatively large exposed length of the model assure that the obtained mean breakdown voltage value is reliable. PD is checked at each LI test.

Based on measurement results the influence of radial stress between windings (in main gap) on axial stress between HV winding discs (coils) at lightning impulse test will be qualified and quantified. Various design criteria will be tested such as simple obtained combined field stress, maximal electric field on the insulated conductor, safety factor along electric field line, stressed space and streamer criterion. Decision between them will be based on logical and theoretical expectations and on their applicability in transformer design process.

Using electric field calculation in this research in addition to measurements on real models, enables better identification of correlation between certain parameters of the physical arrangement (physical model) and parameters that can be retrieved from the field solution. Development of the program for automatic generation of FEM models brought significant benefit to this research because it enabled easier, much faster and much more reliable generation of huge number of different types of models compared to traditional FEM model creation.

7. REFERENCES

- [1] A. Kuchler et al, "Function of Solid Insulation in Transformers", Transform 98, Convention Report, München, 20.-21. April 1998, 41-54.
- [2] <http://www.infolytica.com/en/products/common/script.asp?display=en>, current March 17 2009.
- [3] M. Banović, "Methods for Analysis of Combined Electric Field Stresses", Končar-Electrical Engineering Institute, KPT-B-3/2008, Zagreb, 2008.
- [4] W. Knorr, D Breitfelder, "Breakdown in transformer oil with AC and impulse voltage stress", IEEE Int. Symp. on Electrical Insulation, 1984, 291-296.