

## POWER SUPPLY CHOOSING IN THE NIR MOISTURE METER

Venco Ćorluka, Mirko Filić and Zdravko Valter

*Moisture meter, NIR, near infrared, power supply*

### 1. Introduction

All electronic systems which operate on DC voltages ( $\pm 5V$ ,  $\pm 12V$ , etc.) and are plugged to the AC (220V, 50Hz) system require a power supply. Most of this equipment require not only DC voltage but voltage that also filters and regulates well. A power supply converting AC line voltage to DC power must perform the following functions at high efficiency and at low cost: rectification, voltage transformation, protection, isolation, regulation and power supply noise. Linear regulator provides significant advantages over switching regulators in simplicity, cost, and output noise, but not efficiency. Switching power supplies are becoming popular due to high efficiency and high power density. Line and load regulations are usually better with linear supplies, sometimes by as much as an order of magnitude, but switching power supplies frequently use linear post-regulators to improve output regulation. Advances in operating current, dropout voltage noise and packing have made the modern linear regulator very from the LM317 and LM78XX series for most designs in the past.

### 2. Linear power supply for the nir moisture meter

For operation the NIR moisture meter uses the following voltages and currents:

- $\pm 12V/0,3A$  – supplies integrated circuits
- +24V – Supplies NIR PBS detector
- +5V/0-1A – regulation temperature using thermoelectric cooler of PBS sensor
- +5 - 12V/1A – DC motor power supplies
- +12V/5A – halogen lamp supplies

Figure 1 shows a complete schematic diagram of high current voltage regulator with pass transistor for supplies halogen lamp and DC motor

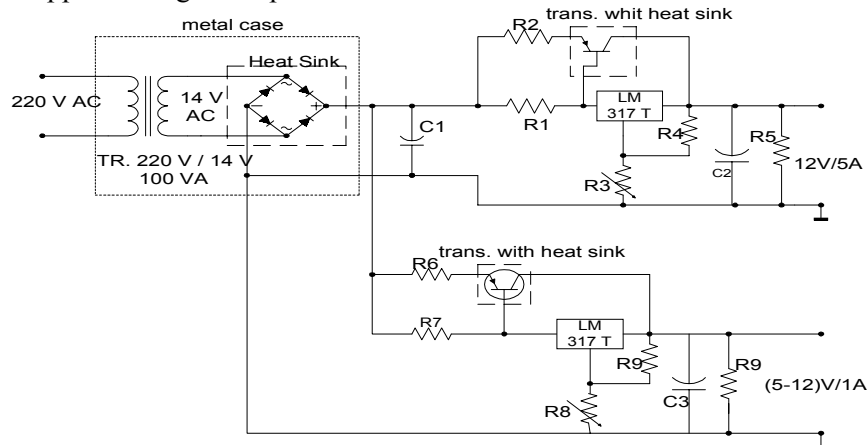

**Figure 1 Light load and DC motor power supply**

Its component functions are: transformer, rectifier, filter and regulator.

- **Transformer.** The first component of the power supply is the transformer. Steps to voltage down or up make voltage level suitable for producing the desired DC output voltage. These occur in all situations and the mains voltage at any point in time will usually be somewhat different from the nominal voltage quoted by the supplier. Any variations of 10% or less can be considered normal and greater variations are not at all uncommon. Since all transformers have losses, these cannot be ignored in the design phase. The iron losses are greatest at no-load and fall as more current is drawn by the transformer. Output power of the transformer (Figure 1) is:  $14V \times 7A = 98VA$ . For light load 50W is now required, 12W for DC motor supplies, 5W for cooling PBS detector. Remain power are: copper loss in the transformer, dissipated power in the pass transistor, full-wave bridge rectifier and the linear regulator.

- **Full-wave bridge rectifier.** Rectifier converts the AC wave to DC. A sinusoidal wave has a “root-mean-square” (RMS) value, equal to a DC value, which would deliver the same amount of power into a resistive load. For a sinusoidal wave form with a peak value,  $V_{peak}$  :

$$V_{rms} = 0.707 \times V_{peak} \quad (1)$$

Its DC value is twice that of the half-wave rectifier:

$$V_{fv} = 0,636 \times V_{peak} \quad (2)$$

Full winding utilisation means that the AC current is now the same as for a bridge rectifier, at 1,8 times the DC current, but only for a common mode load.

- **Filter** smoothes the AC ripple in the rectified waveform. The pulsating DC as shown generally is not suitable for powering circuits, because they need a more constant voltage. Another way of describing the filter effect is that it suppresses the AC components in the waveform, leaving the DC and some residual AC (ripple). For light load; a capacitor alone may be sufficient.

- **Linear regulator** Voltage regulators comprise a class of widely used ICs. These units contain the circuitry for reference source, error amplifier, control device, and overload protection all in a single IC chip. We will examine operation using some of the popular 3-terminal fixed voltage regulators and those allowing an adjustable output voltage. The LM317 is an adjustable 3-terminal positive voltage regulator capable of supplying in excess of 1.5A over an output range of 1.25 to 37 volts. Selection of resistors  $R_3$  and  $R_4$  for light load, these  $R_8$  and  $R_9$  for DC motor (Figure 1) allow the setting of the output to any desired voltage over the adjustment range. The output voltage desired can be calculated using:

$$V_0 = V_{ref} \left( 1 + \frac{R_3}{R_4} \right) + I_{adj} \quad (3)$$

With typical values of:  $V_{ref} = 1,25V$  and  $I_{adj} = 100\mu A$ . High current regulated supply with the LM317 regulator and pass transistor are schematically represented in Figure 1. Using additional power transistor to share a portion of the total current can increase the LM317 output. The amount of current sharing is established with a resistor placed in series with the emitter of the 2 X pass transistor. In the Figure 1 the pass transistor will start conducting when the LM317 current reaches about 0,1A, due to the voltage drop across the 22 Ohm resistor. Current limiting occurs at about 0,1A for the LM317 which will drop about 2,2V across the 22 Ohm resistor and produce a 1V drop across the 0,47 Ohm emitter resistor. Thus the total current is limited to about  $0,1 + 2 \times 1/0,47 = 4,25A$ .

## 2.1 DC motor power supply

DC motors generally differ from electronic loads in three respects: They have appreciable inductance, they draw more power and they need constant current rather than constant voltage. Often the power supply for a DC motor relies on the inherent inductance to smooth the current,

thereby eliminating the smoothing capacitor. In Figure 1 power supply for DC motor is shown. Scheme and analysis is similar to supplies light load.

## 2.2 Power supply NIR PBS detector

Figure 2 shows fixed positive voltage regulator of the series 78, which provides excited voltage 24V for supplies PBS detector. The LM78XX series is a three terminal positive regulator for a wide variety of applications including local, on-card regulation. The fixed voltage regulator has an unregulated voltage,  $V_{in}$  applied to one terminal, delivers a regulated output voltage,  $V_o$  from a second terminal, with the third terminal connected to ground. A rectified and filtered unregulated DC voltage is the input  $V_{in}$ . Capacitor connected from input or output to ground helps to maintain the DC voltage and additionally to filter any high frequency voltage variation. The output voltage is then available to connect to the load. The line transformer safety is isolated from the line voltage. A line frequency transformer is used to convert the hazardous line voltage to an isolated safe low voltage.

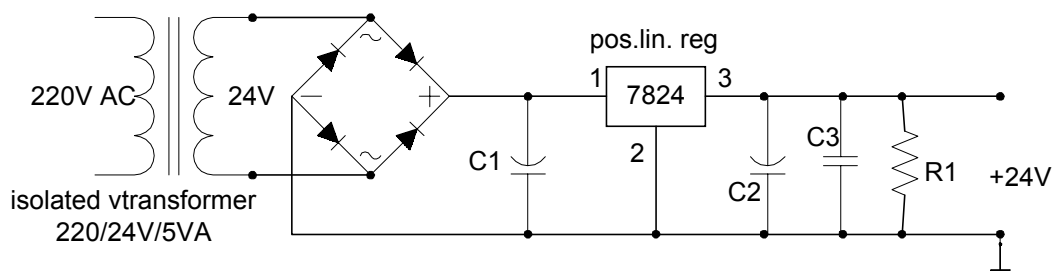

Figure 2 Positive output 24V power supply

## 2.3 Dual output power supply

Bipolar power supply was built using the notes for LM7812 and LM7912. A centre tapped 24 volts transformer was used to step down line voltage, then rectified, smoothed and regulated. Negative voltage regulator IC<sub>s</sub> is available in the 79 series, which provides a series of IC<sub>s</sub> similar to the 78 series but operating on negative voltages, providing a regulated negative output voltage. Operation with a load common a regulator powers a load which is not connected to ground but instead is connected at a voltage source of opposite polarity (e.g. op-amps, level shifting circuits etc.) as shown in Figure 3.

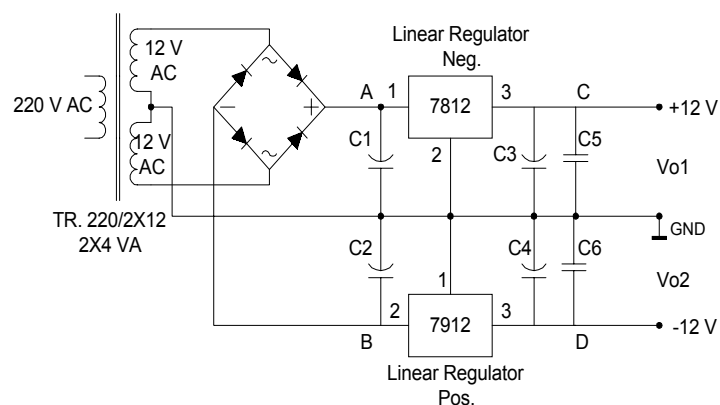

Figure 3 Dual (positive and negative) ±12V output power supply

### 3. Power supply requirement

#### 3.1 Ripple

The DC voltage derived from an AC source signal by rectifying and filtering will have some variation (ripple). The smaller the AC variation with respect to the DC level the better the filter circuit operation. The output voltage of the filter circuit is measured using a DC voltmeter and a AC (rms) voltmeter.

$$r = \frac{V_{r(rms)}}{V_{dc}} 100 \quad (4)$$

Where  $V_{r(rms)}$  ripple voltage (rms) and  $V_{dc}$  DC voltage in volts. From an analysis of this voltage waveform the following relation can be obtained

$$V_{dc} = V_m - \frac{V_{r(p-p)}}{2} \quad (5)$$

$$V_{r(rms)} = \frac{V_{r(p-p)}}{2\sqrt{3}} \quad (6)$$

$$V_{r(rms)} = \frac{2,9I_{dc}}{C} \quad (7)$$

Analyze the operation of the +12V voltage supply in Figure 1 operating into a load drawing 4200mA.

The transformer steps down the line voltage from 220V, rms to a secondary voltage of 14V rms across each transformer half. This results in a peak voltage across the transformer of:

$$V_m = 1,41 \times V_{rms} = 1,41 \times 14 = 19,8V, \quad V_{r(rms)} = \frac{2,9I_{dc}}{C} = 2,9 \times 4200/25000 = 0,48V \text{ and the } V$$

peak ripple voltage is then:  $V_{r(peak)} = 1,73 \times V_{r(rms)} = 1,73 \times 0,48 = 0,831V$ . The DC level of the voltage across the capacitor C is:  $V_{dc} = V_m - V_{r(peak)} = 19,8 - 0,831 = 18,969V$  The ripple voltage is

then:  $r = \frac{2,9I_{dc}}{CV_{dc}} \times 100\% = 2,6\%$  The voltage across filter capacitor has a ripple of about 2,6% and

drops to a minimum voltage of:  $V_{in(min)} = V_m - 2V_{r(peak)} = 18,38V$ . The amount of ripple voltage would also be small for a light load. The capacitor also affects the peak current through the rectifying diode and as will now be shown, the larger the value of capacitor used the larger the peak current through the rectifying diode.

#### 3.2 Regulation

Voltage change is described by a factor called: voltage regulation:

$$V.R. = \frac{V_{NL} - V_{FL}}{V_{FL}} \times 100\% \quad (8)$$

Where  $V_{NL}$  voltage at no load and  $V_{FL}$  voltage at full-load. The DC voltage supply for light load (Figure 1) provides 12V when the output is unloaded. When full load current is down from the

supply, the output voltage drops to 11,8V. Voltage regulation is:  $V.R. = \frac{V_{NL} - V_{FL}}{V_{FL}} \times 100\% =$

1,69 % If the value of full load voltage is the same as the no load voltage, the *V.R.* calculated is 0% which is the best to expect.

### 3.3 Ripple rejection ratio (PSRR)

Ripple rejection ratio is defined to the ratio of output voltage ripple to input voltage ripple:

$$PSRR = 20 \log \left( \frac{\Delta V_{in}}{\Delta V_0} \right) \text{ (dB)} \quad (9)$$

For supply of light load (Figure 1) measured voltages  $\Delta V_0$  and  $\Delta V_{in}$  at frequency 100Hz are:  $\Delta V_{in} = 30 - 18 = 12\text{V}$ ,  $\Delta V_0 = 0,48 - 0,46 = 20\text{mV}$ , ripple rejection is:  $PSRR = 20 \log \left( \frac{\Delta V_{in}}{\Delta V_0} \right) = 55,56\text{(dB)}$

### 3.4 Noise

Linear supplies should filter out noise. Noise in a circuit can be divided into two types:

- Extrinsic noise: Noise, which arises from a source external to the circuit under consideration and is coupled in somehow.

- Intrinsic noise: Noise generated within the circuit elements.

Measure the noise on the regulators output and compute the noise rejection in dB:

$$NR = 20 \log \frac{V_{Nout}}{V_{Nin}} \quad (10)$$

Noise rejection of the circuit shown in Figure 2 is:  $NR = -46,7 \text{ (dB)}$  where  $V_{Nout} = 0,645\text{(mV)}$  and  $V_{Nin} = 140 \text{ (mV)}$  measured at frequency 100 Hz.

### 3.5 Efficiency

Efficiency is defined as  $P_{out}/P_{in}$ . Series regulated power supply are not efficient and in some cases dissipated a lot of power. For example, the output voltage of power supply with pass transistor (Figure 1) is 12V, of a bridge rectifier designed to give 19V DC and current across transistor is about 4A, the output power is 48W ( $P_{out}$ ), the power consumed by the transistor is  $(19-12)\text{V} \times 4\text{A} = 28\text{W}$  and the bridge rectifier therefore delivers 76W ( $P_{in}$ ). Thus the power supply efficiency  $P_{out}/P_{in} = 48/76 = 63\%$  which is good. However, if the output voltage is 5V as in Figure 1 for DC motor and current is 1A, this results in a poor regular efficiency ( $P_{out}/P_{in}$ ) = of  $5\text{W}/19\text{W} = 26.3\%$ .

### 3.6 Thermal analysis and heat sink

Semiconductors have definite operating temperature limits. Heat flow from a higher temperature to a lower temperature region, and the quantity that resists this flow of heat energy is called **thermal resistance**. Thermal resistance  $\Theta_t$  is defined as the ratio of temperature rise in degrees centigrade to the power conducted in watts. Therefore, the junction temperature can be related to the power being dissipated  $P_d$ . The thermal resistance  $\Theta_t$  and the ambient temperature  $T_a$  by the following equation:

$$\Theta_t = \frac{T_j - T_a}{P_d} \text{ (}^\circ\text{C/W)} \quad (11)$$

For example (Figure 1) power transistor BJT (TO-3 case) has a rated maximum total power dissipation ( $P_{dmax}$ ) of 100W at a case temperature ( $T_c$ ) of 25 °C, and the maximum operating junction temperature ( $T_{jmax}$ ) is 200 °C. When the case temperature of this transistor is 200 °C (i.e. when  $T_c = T_{jmax}$ ), then this transistor can dissipate zero power, since any dissipation would cause the junction temperature to rise even further exceeding the maximum permissible. Thermal resistance from junction to case, we may calculate that  $\Theta_{jc} = (200-25)/100 = 1,75^\circ\text{C/W}$ . Assume the heat sink used has a sink-to-ambient thermal resistance  $\Theta_{sa} = 1.5^\circ\text{C/W}$ , case-to-sink thermal resistance  $\Theta_{cs} = 0.5^\circ\text{C}$  and temperature ambient of 40°C calculate all the relevant temperature:  $T_s = T_a + P_d \times \Theta_{sa} = 40 + 28 \times 1.5 = 82^\circ\text{C}$ ,  $T_c = T_s + P_d \times \Theta_{cs} = 82 + 28 \times 0,5 = 96^\circ\text{C}$ ,  $T_j = T_c + P_d \times \Theta_{jc} = 96 + 28 \times 1,75 = 145^\circ\text{C}$ . The actual junction temperature is 145 °C, which is well below the rated maximum junction temperature of 200 °C hence the heat sink arrangement used is adequate.

#### 4. Conclusion

Linear regulators are relatively simple and effective, offer low ripple, but can have problems with heat dissipation and efficiency. They may have lower ripple, better regulation, and faster response to transient loads. The size of the transformer is a function of a number of items: output power, load regulation, efficiency, maximum allowable temperature rise and cost. The linear regulator exceptional rejection of the 100 Hz ripple voltage found at the output of the transformer as long as the voltage does not go below the dropout voltage of the linear regulator. Real power supplies can cause noise and spurious oscillations that can force the designer into a frustrating glitch hunt. Bypassing and decoupling are often poorly applied. Bypassing is used to reduce the noise current on power supply lines. Decoupling is the isolation of two circuits on common line.

#### References

- [1] Charles L. Alley & Kenneth W. Atwood, «Electronic engineering» Electrical Engineering Department University of Utah 1980, ISBN 0-471-02450-3
- [2] Arthur H. Seidman & Jack L. Waintraub, « Electronics Devices Discrete and Integrated Circuits» , Charles E. Merrill Publishing Company Columbus , Ohio 1979, ISBN 0-675-8494-6
- [3] Bruce Carlson, A., David Gisser, G., “Electrical Engineering “, Concept and applications, Second edition, Rensselaer Polytechnic Institute, Addison-Wesley Publishing Company, New York, Ontario

Venco Corluka

Faculty of Electrical Engineering, University of Osijek, Croatia

Kneza Trpimira 2b, HR-31000 Osijek, E-mail: venco.corluka@etfos.hr

Mirko Filic

Faculty of Electrical Engineering, University of Osijek, Croatia

Kneza Trpimira 2b, HR-31000 Osijek, E-mail: Mirko.Filic@etfos.hr

Zdravko Valter

Faculty of Electrical Engineering, University of Osijek, Croatia

Kneza Trpimira 2b, HR-31000 Osijek, E-mail: zvalter@etfos.hr